

MJ Filter



MJ Filter



MJB Filter Feature

**Metal • Cement • Powder Bulk • Welding • Plastic
Petro-Chemical • Pharmaceutical • Food**

A range of reverse jet cleaned tubular bag filters, suitable for extracting dust from continuous processes. They may operate as free standing filter units complete with hopper and discharge devices, or as open base flanged units for mounting on silos or other vessels.



750 - 35,000 m³/h

- Suitable for collection of most fine dusts including metal grinding, welding fumes and most powders.
- Robust welded steel construction.
- Bag replacement from clean air side.
- Weatherproof for exposed locations.
- Full range of filter materials available.
- ATEX compliant for explosion dusts in categories St1, St2, and St3.
- Build-in pre-separation with down flow / cross flow air distribution.
- Wide range of efficient Combifab fans.
- Normal maximum working temperature 80°C.
- Normal maximum negative pressure 8000 Pa.
- Normal maximum positive pressure 2000 Pa.
- Cleaning controller type NF8HD250 in IP65 enclosure, supply voltage 230/220/110V.
- Typical air flow volumes up to 35,000 m³/h per single filter unit. Larger units available upon request.

How MJB Filter works

...during normal operation

1. During normal operation, the dust laden air from the plant travels down the supply duct 1
2. A vertical slotted baffle 2 separates the inlet section that slows the airstream and directs dust downward into the hopper, 3 protecting the bags from direct abrasion but allowing air to pass horizontally between the bags.
3. The lighter dust collects on the outside of the tubular bag 4 as clean air passes through to the inside of the bags to the clean air chamber 6. Finally, the clean air travels through the air outlet 6 where it may be returned to the plant or exhausted outdoors 5.
4. The heavier dust settles in the hopper section 3 where it can be discharged into a metal bin 7 or other waste discharge system.

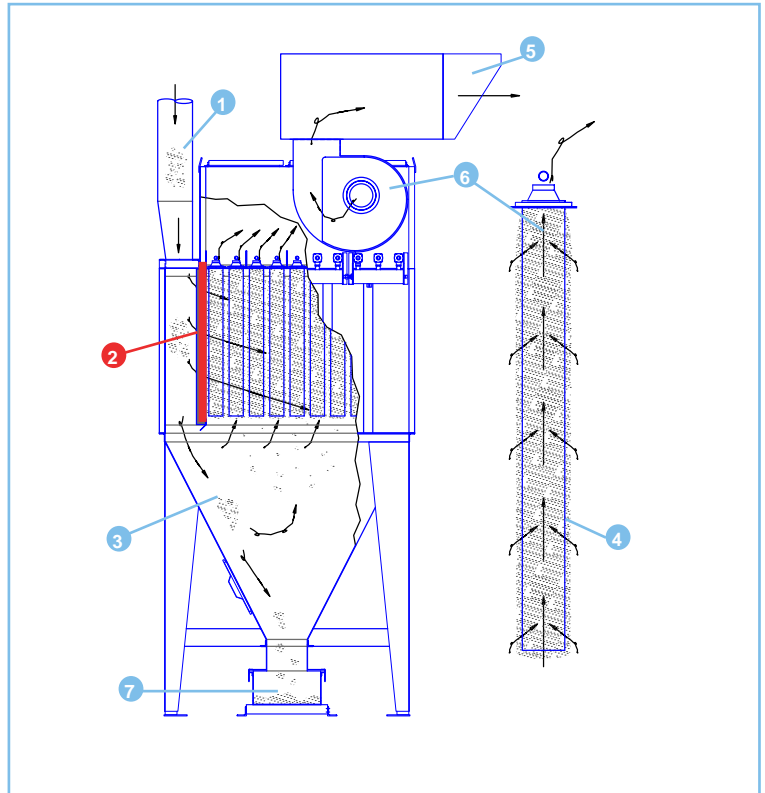

...while cleaning

1. The MJB can utilize a differential pressure gauge to control the compressed air cleaning. In essence, the filter cleans itself when it needs to!
2. A compressed air line must be connected to one end of the compressed air manifold 8
3. A solenoid valve opens to allow compressed air from the manifold into the jet tubes 9. The jet tubes are aligned above each row of filter bags.
4. The downward blast 10 blows the dust off the tubular filter bag (from the inside out) 4 where it settles into the hopper section 3 to be collected in the metal bin 7 or other waste discharge system.

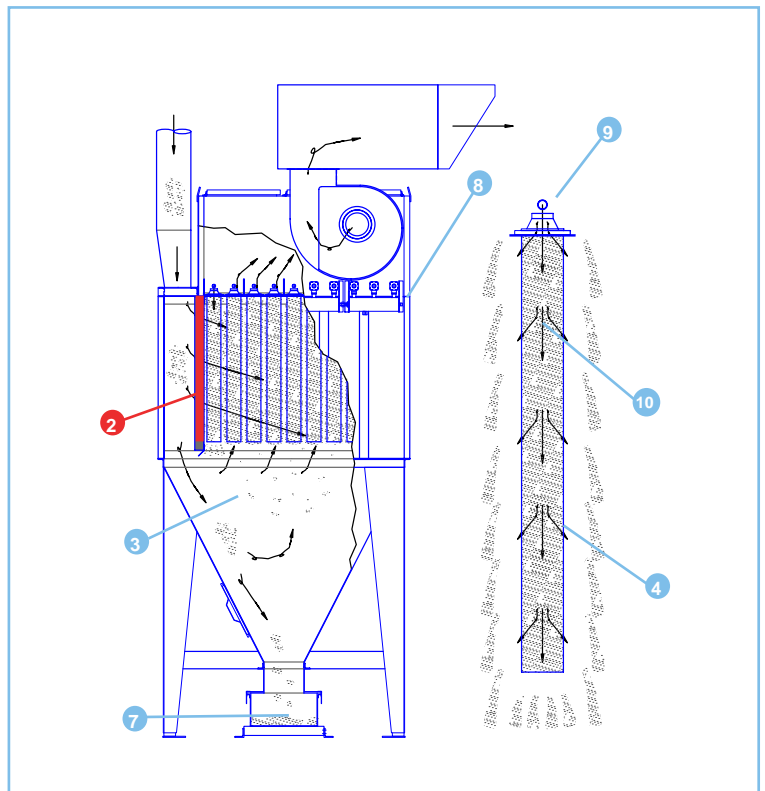

MJB Filter

Technical and Dimensions

Dimension F: From the bottom of the clean air chamber to the top of the silencer (Weight of the fan and silencer).

Fan up to 3 kW: F = 1386 mm (67 kg)
 Fan from 4 to 7.5 kW: F = 1685 mm (108 kg)
 Fan from 7.5 to 18.5 kW: F = 1850 mm (188 kg)

Length of Filter Bags
 Type S = 1000 mm
 Type M = 1315 mm
 Type L = 2000 mm
 Type XL = 2400 mm

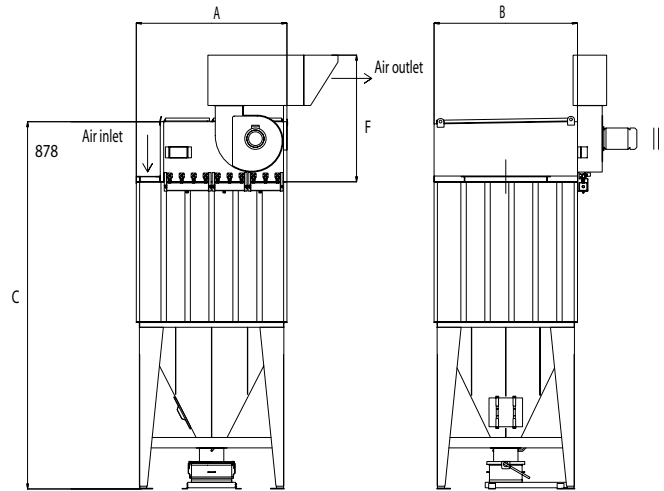

MJB-L Filter

Technical parameters				Dimensions		
Type	Number of filter bags	Filter area m ²	Typical maximum airflow volume m ³ /h	A	B	C
				Width	Depth	Height
MJB 14/L/36	18	14	1500	1150	1220	4395
MJB 19/L/46	24	19	2000	1150	1220	4395
MJB 19/L/38	24	19	2000	1150	1570	4595
MJB 26/L/48	32	26	2800	1150	1570	4595
MJB 32/L/58	40	32	3500	1500	1570	4755
MJB 35/L/4-11	44	35	3800	1150	2095	5195
MJB 38/L/68	48	38	4100	1500	1570	4755
MJB 44/L/78	56	44	4800	1850	1570	4935
MJB 44/L/5-11	55	44	4800	1500	2095	5195
MJB 50/L/88	64	50	5400	1850	1570	4935

Technical parameters				Dimensions		
Type	Number of filter bags	Filter area m ²	Typical maximum airflow volume m ³ /h	A	B	C
				Width	Depth	Height
MJB 52/L/6-11	66	52	5600	1500	2095	5195
MJB 60/L/7-11	77	60	6500	1850	2095	5195
MJB 70/L/8-11	88	70	7600	1850	2095	5195
MJB 78/L/9-11	99	78	8400	2200	2095	5365
MJB 87/L/10-11	110	87	9400	2200	2095	5365
MJB 94/L/11-11	121	94	10200	2550	2095	5195
MJB 104/L/12-11	132	104	11300	2550	2095	5195
MJB 120/L/14-11	154	120	13000	3250	2095	5195
MJB 140/L/16-11	176	140	15200	3600	2095	5195

MJB-XL Filter

Technical parameters				Dimensions		
Type	Number of filter bags	Filter area m ²	Typical maximum airflow volume m ³ /h	A	B	C
				Width	Depth	Height
MJB 23/XL/38	24	23	2500	1150	1570	4995
MJB 31/XL/48	32	31	3400	1150	1570	4995
MJB 38/XL/58	40	38	4100	1500	1570	5155
MJB 42/XL/4-11	44	42	4550	1150	2095	5595
MJB 46/XL/68	48	46	5000	1500	1570	5155
MJB 52/XL/5-11	55	52	5600	1850	1570	5335
MJB 54/XL/78	56	54	5900	1500	2095	5595
MJB 60/XL/88	64	60	6500	1850	1570	5335
MJB 63/XL/6-11	66	63	6800	1500	2095	5595

Technical parameters				Dimensions		
Type	Number of filter bags	Filter area m ²	Typical maximum airflow volume m ³ /h	A	B	C
				Width	Depth	Height
MJB 74/XL/7-11	77	74	8000	1850	2095	5595
MJB 84/XL/8-11	88	84	9100	1850	2095	5595
MJB 94/XL/9-11	99	94	10200	2200	2095	5765
MJB 105/XL/10-11	110	105	11400	2200	2095	5765
MJB 115/XL/11-11	121	115	12500	2900	2095	5595
MJB 125/XL/12-11	132	125	13500	2900	2095	5595
MJB 145/XL/14-11	154	145	15700	3250	2095	5595
MJB 165/XL/16-11	176	165	17900	3600	2095	5595
MJB 190/XL/18-11	198	190	20600	3950	2095	5765
MJB 210/XL/20-11	220	210	22700	4300	2095	5765

Key example : MJB 14 / L / 36

14	Filter area m ²
L	Filter bag height
36	Number of cleaning valve (3) and number of bag per valve (6)

MJB Filter Material



There are materials to resist attack from acidic and alkaline atmospheres; with enhanced abrasion resistance; for higher temperatures; with anti-static properties; with flame retardant treatments and with other special properties.

Needlefelt can be made from many other kinds of fiber for example:

- Polypropylene (PP)
- Polyamide (NOMEX)
- Polyphenyl Sulphide (PPS) (Ryton)
- Polyimide (P84)
- Homopolymer-acrylic (PAN) (Dralon)
- PTFE (Gore-Tex) (Ravlex)

MJB reverse jet tubular bag filters typical utilize robust high efficiency nonwoven needlefelt materials incorporating a woven scrim for stability, with various finishes to suit the application and materials to be filtered or collected.

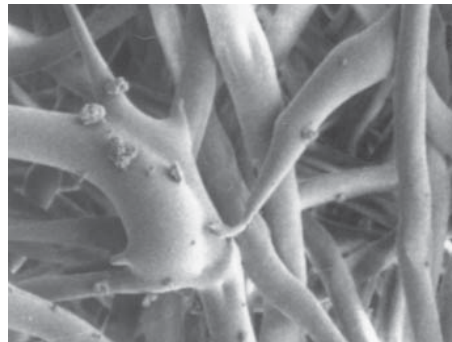

Self supported (scrimless) materials are economic for many general applications.

Typical cross section of a used needlefelt with scrim

The material may have a glazed dust collection surface. This improves the dust release properties for use with "difficult" dust materials. This is shown here magnified.

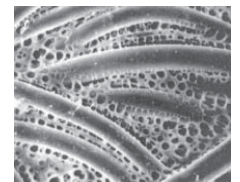
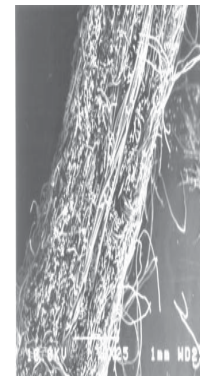
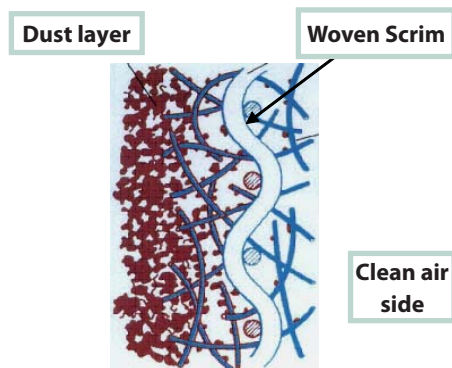

Ravlex PTFE surface

The basic material is polyester needlefelt with a singed dust collection surface. However, many other base materials are available to suit particular applications.

Typical standard filter materials

Type	Material	Weight g/m ²	Permeability under 200 Pa (m ³ /m ² /h)	Characteristics
NF100	Polyester	500	1800	Singed
NF130	Polyester	500	1050	Glazed oil/water resistant *
NF142	Polyester	500	750	Glazed, antistatic, oil/water resistant *
NF301	Polyester	300	2200	Standard finish
NF304	Polyester	300	1550	Glazed

Many other types available for particular applications upon request.

The residual dust emissions will depend upon on the filter speed, the dust loading and the efficiency when filtering the particular dust and other characteristics relating to the application, operating conditions and dust type

* For higher humidity or slightly oily dusts.

MJC Filter Feature

***Metal • Cement • Powder Bulk • Welding
Plastic • Petro-Chemical • Pharmaceutical • Food***

A range of reverse jet cleaned cartridge filters, suitable for extracting dust from continuous processes. They may operate as free standing filter units complete with hopper and discharge devices, or as open base flanged units for mounting on silos or other vessels.



2,000 - 65,000 m³/h

- Suitable for many different applications that generate light to heavy volumes of any dust.
- Robust, long lasting welded steel construction for tough industrial environments.
- Cartridge replacement from clean air side.
- Weatherproof for exposed locations.
- ATEX compliant for explosive dusts in categories St1, St2 and St3.
- Built-in pre-separation with down flow / cross flow air distribution.
- Wide range of integral fans from 0.75kW to 18.5 kW.
- Normal maximum working temperature 80°C.
- Normal maximum negative pressure 8000 Pa.
- Normal maximum positive pressure 2000 Pa.
- UniClean Patented cartridges for maximum efficiency. Cleaning controller type NF8HD250 in IP65 enclosure, supply voltage 230/220/110V.
- Typical air flow volumes up to 65000 m³/h per single filter unit. Larger units available upon request.

How MJC Filter works

...during normal operation

1. During normal operation, the dust laden air from the plant travels down the supply duct 1.
2. A vertical slotted baffle 2 separates the inlet section that slows the air stream and directs dust downward into the hopper 3, protecting the cartridges from direct abrasion but allowing air to pass horizontally between the cartridges.
3. The lighter dust collects on the outside of the filter cartridges 4 as clean air passes through to the inside of each cartridges. Finally, the clean air travels through the air outlet 6 where it may be returned to the plant or exhausted outdoors 5.
4. The heavier dust settles in the hopper section 3 where it can be discharged into a metal bin 7 or through a rotary air valve.

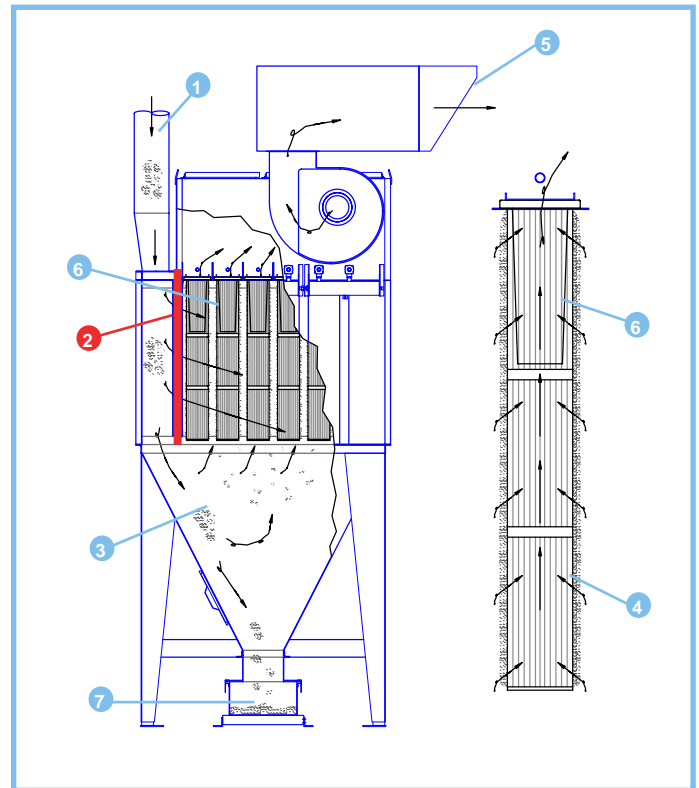

...while cleaning

1. The MJC can utilize a differential pressure gauge to control the compressed air cleaning. In essence, the filter cleans itself when it needs to!
2. A compressed air line must be connected to one end of the compressed air manifold 8.
3. A solenoid valve opens to allow compressed air from the manifold into the jet tubes. The jet tubes are aligned above each row of the filter cartridges 9.
4. The downward blast 10 blows the dust off the cartridges (from the inside out) 4 where it settles into the hopper section 3 to be collected in the metal bin 7 or other waste discharge system.

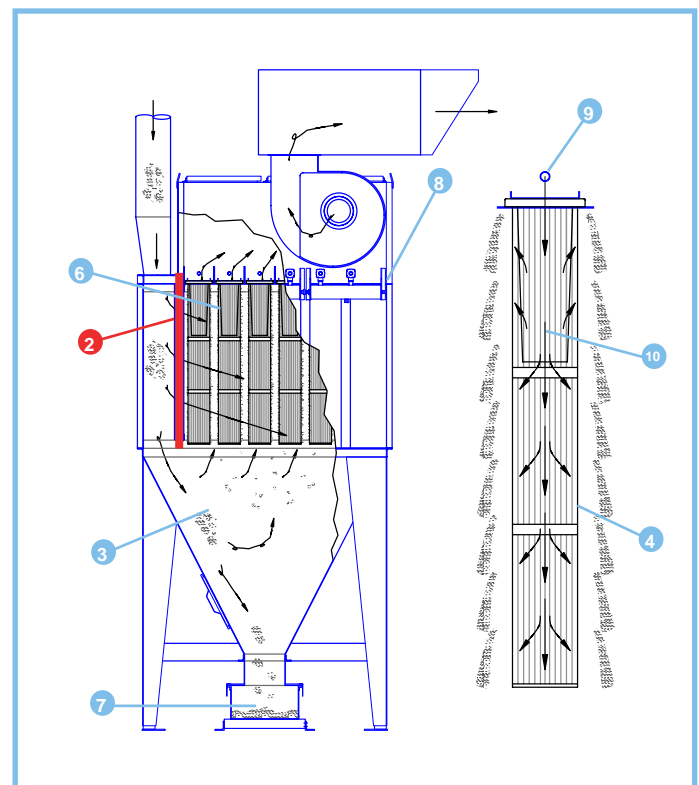

MJC Filter

Technical and Dimensions

Dimension F: From the bottom of the clean air chamber to the top of the silencer

(Weight of the fan and silencer).

Fan up to 3 kW:

F = 1386 mm (67 kg)

Fan from 4 to 7.5 kW:

F = 1685 mm (108 kg)

Fan from 7.5 to 18.5 kW:

F = 1850 mm (188 kg)

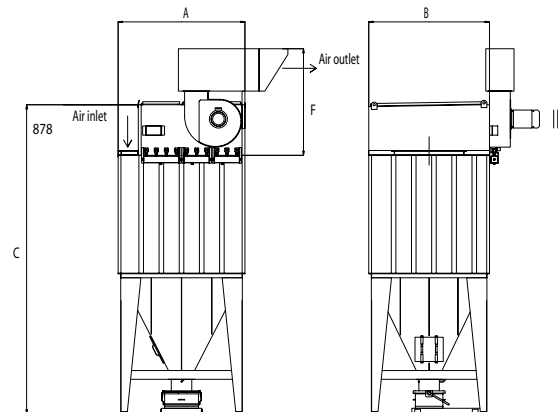

MJC - 40 type filter

Technical parameters				Dimensions			With pre-separation section located on
Type	Number of filter bags	Filter area m ²	Typical maximum airflow volume m ³ /h	A	B	C	
				Width	Depth	Height	
MJC 48/40/43	12	48	4600	1150	1220	3395	Right or left side
MJC 64/40/44	16	64	6100	1500	1570	3755	Right or left side
MJC 80/40/54	20	80	7700	1850	1570	3935	Right or left side
MJC 96/40/38	24	96	9200	1500	2095	4195	In the middle
MJC 128/40/48	32	128	12300	2200	2095	4365	In the middle
MJC 160/40/58	40	160	15400	2550	2095	4195	In the middle
MJC 192/40/68	48	192	18400	2550	2095	4195	In the middle
MJC 224/40/78	56	224	21500	2900	2095	4195	In the middle
MJC 256/40/88	64	256	24600	3250	2095	4195	In the middle
MJC 288/40/98	72	288	27600	3600	2095	4195	In the middle

MJC - 66 type filter

Technical parameters				Dimensions			With pre-separation section located on
Type	Number of filter bags	Filter area m ²	Typical maximum airflow volume m ³ /h	A	B	C	
				Width	Depth	Height	
MJC 60/66/33	9	60	5700	1150	1220	3765	At rear
MJC 79/66/43	12	79	7600	1150	1220	3765	At rear
MJC 105/66/44	16	105	10100	1500	1570	4125	At rear
MJC 132/66/54	20	132	12700	1850	1570	4305	At rear
MJC 158/66/38	24	158	15200	1500	2095	4565	Right or left side
MJC 211/66/48	32	211	20200	2200	2095	4735	Right or left side
MJC 264/66/58	40	264	25300	2550	2095	4565	Right or left side
MJC 316/66/68	48	316	30300	2550	2095	4565	Right or left side
MJC 369/66/78	56	369	35400	2900	2095	4735	Right or left side
MJC 422/66/88	64	422	40500	3250	2095	4565	Right or left side
MJC 475/66/98	72	475	45600	3600	2095	4565	Right or left side
MJC 528/66/10-8	80	528	50700	4300	2095	4565	In the middle
MJC 580/66/11-8	88	580	55700	4650	2095	4565	In the middle
MJC 634/66/12-8	96	634	60700	4650	2095	4565	In the middle
MJC 686/66/13-8	104	686	65800	5000	2095	4565	In the middle
MJC 739/66/14-8	112	739	70900	5700	2095	4735	In the middle

Key example: MJC 48/40/43

48	Filter area m ²
40	Cartridge of 4.0 m ² per unit (66 = 6.6 m ²)
43	Number of cleaning valve (4) and number of cartridge per valve (3)

MJC Filter Material



At the heart of every MJC cartridge filter is the UniClean patent pleated cartridge element.

The overall dimensions, including pleat depth and spacing were designed uniquely for the MJC range. More than ten year's experience in many applications and the more recent introduction of the UniClean feature ensure maximum performance and long life.

The MJC range uses a **Type 40** with 4.0m² or a **Type 66** with 6.6m² per element.

Filter materials are:

- **CA100** high quality thermal bonded polyester pleated fabric as standard.
- **CA140**, similar to CA 100, with adding metalized antistatic treatment.
- **CA190**, similar to CA100, with adding PTFE treatment for ease of dust release (sticky dust)
- **CA175** is 80% cellulose, 20% polyester material available to special order.



Surface filtration

The filter media is typically around 1.7mm thick but contains many layers of random fibers. Filtration occurs at or very near the surface of the materials and its efficiency (BIA class U, S, G, and C) may be further enhanced by a surface layer of dust. For light dust loads, or very fine dust, it may be beneficial to pre-coat the filter by introducing used dust, or a special pre-coat material.

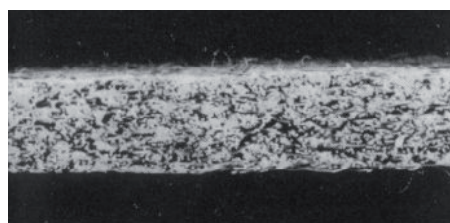

Cross section CA100

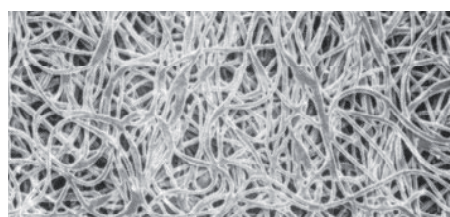

Surface magnified x 200

UniClean® in detail

UniClean® provides more uniform cleaning air pressure over the whole cartridge during pulse cleaning. With conventional cartridges, the thick dust layer tends to form at the top section of the filter due to uneven and ineffective pulse cleaning and cause less filtration area.

The UniClean® concept overcomes this problem, dust accumulations being directed towards the middle of the cartridge. Another advantage is that it guarantees uniform cleaning pressure, as explained above.

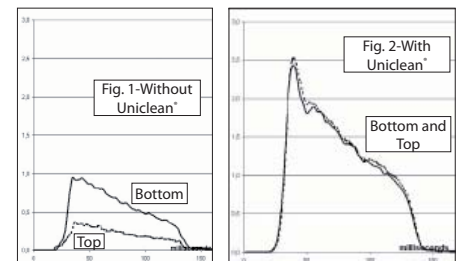

The internal air cleaning pressure is considerably higher than conventional cartridges with a similar reverse jet cleaning system. (Compare figures 1 and 2).

Effective cleaning reduces the number of cleaning impulses required. Consequently, the lifetime of the filter medium is longer and energy consumption for cleaning lower.

Patents

Germany: 19909075.0

International: PCT/EP00/01801

MJ Filter

Integral Fans for MJ Filter

MJ units may be fitted with space saving integral high efficiency radial fans. Single fans can deliver up to 14,000 m³/h but some larger units may be fitted with two fans. A floor mounted version of the same fan range is also available as an option.



Combifab fan can be arranged in direct drive or belt driven to suit the installation site and impeller speed. Variable speed inverter is available upon specified.

- Airflow volumes up to 70,000m³/h
- High efficiency up to 87%

Fans for larger installations

Larger installations may be served by separately mounted Dantherm Filtration Combifab fans when appropriate. Combifab is a range of high efficiency low noise fans.

The clean air impeller, Combifab Type R is closed bladed impeller with backward curved blades. It is the most suitable for MJ filter unit.

Floor mounted larger Combifab will be more practical and cost effective solution compared to multiple integral fan to meet the higher air volume demand.

MJ Filter Options

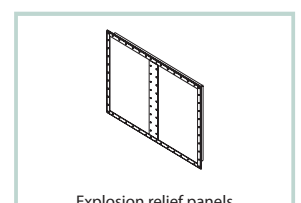
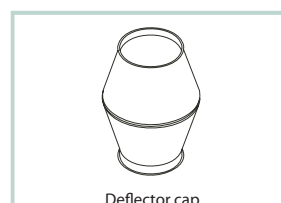
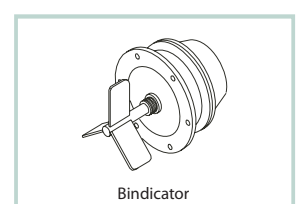
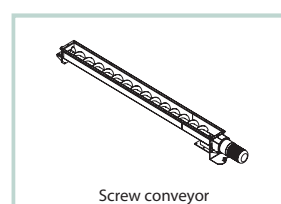
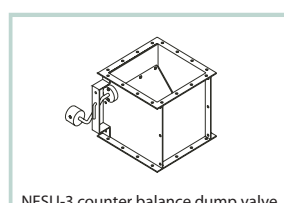
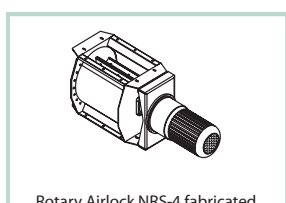
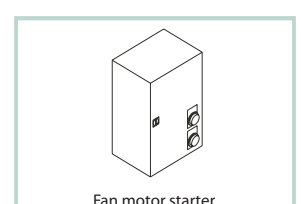
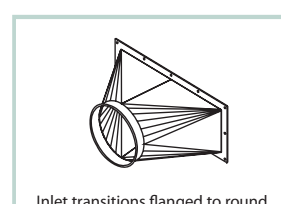
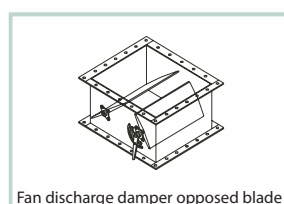
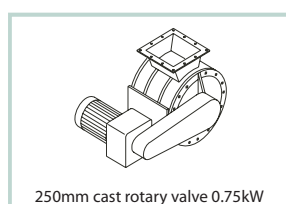
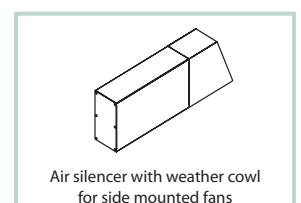
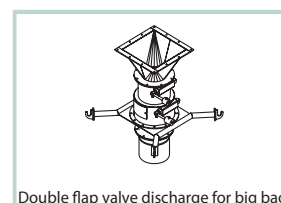
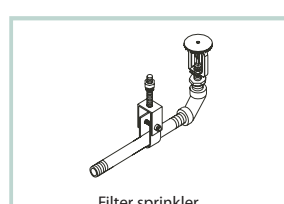
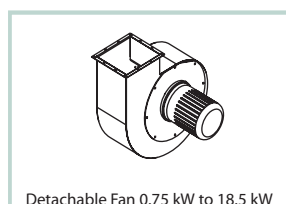
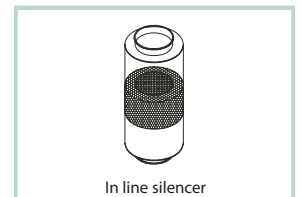
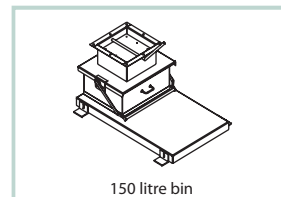

Application

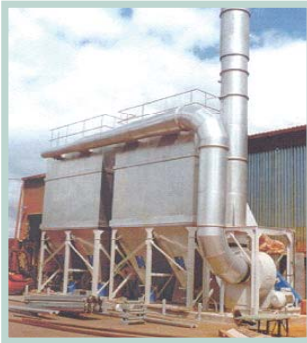

Fume extraction from hot-dip galvanizing process



Conveying and handling hydrated lime for steel production



Extraction from rice polishing

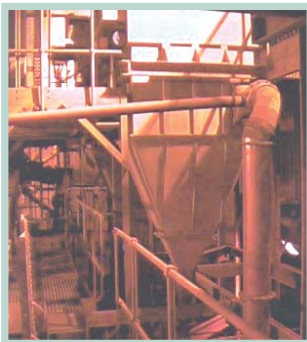

Cement uploading and conveying for production and distribution



Extraction of cleaning and packing process from rice mill, Agriculture industry



Cutting, trimming and finishing gypsum products



Conveying and Transferring chrome ore at high temperatures



Dockside handling, conveying and storage, of grain



Cement Plant / Belt Conveyor Process, Cement / Lime industry

Applications for wide range of process include:

Industry
<ul style="list-style-type: none"> - All powder, pellets and granulated material - Agriculture - Ceramic - Chemicals & Pharmaceutical - Food processing - Foundry - Galvanizing - Metal & Casting - Shot blast - Surface finishing, decorative coating ... and many more

Process
<ul style="list-style-type: none"> - Conveying, mixing, blending - Bag filling and emptying - Blast cleaning - Crushing, screening, sieving - Milling - Melting and sand reclamation to fettling and finishing - Hot metal processes - Grinding, polishing, finishing - Machines and booths. - Powder coating

World wide sales companies



The world leader in air pollution control

Dantherm Filtration focuses on individual solutions for individual customer needs. We benefit from the experience and expertise of more than 40,000 air cleaning systems. And we deliver unbeatable reliability, low energy consumption and compliance with all

mandatory requirements for a wide range of applications in many different industries all over the world.

Dantherm Filtration is part of the Dantherm Group, a leader in industrial air management,

offering industrial cooling, heating dehumidification, ventilation, air filtration and mobile air management. The group has 3,000 employees and operates globally with production and sales companies in Europe, the US and Asia.



Dantherm Filtration Co.,Ltd.

Thailand

Tel: +66 (0) 2715 1300

Fax: +66 (0) 2715 1301

Dantherm Filtration Co.,Ltd.

Vietnam

Tel: +84 8 3526 5541

Fax: +84 8 3526 5541

Dantherm Filtration Co.,Ltd.

Malaysia

Tel: +60 (0) 3 7804 6386

Fax: +60 (0) 3 7804 6412

info.th@danthermfiltration.com
www.danthermfiltration.com

