

AUTO - M Shaker Filter

AUTO M

Features



Suitable for a wide variety of applications that generate light to medium volumes of dry dust.

500 to 11,500 m³/h

According to application

- The latest development of the well proven Auto M automatic shaker filter series.
- Restyled to be easier to service.
- Clean air side maintenance to make bag changing and servicing a healthier task.
- Pre-wired fan and shaker motors to speed installation.
- No need for compressed air.
- Compact dimensions, with minimal height requirement.
- Wide range of sizes from 7.5 to 90 m² filter area.
- Weatherproof for location almost anywhere.
- Suitable for potentially explosible dusts in categories St1, St2 and St3, with explosion relief panels fitted.
- Combination of filter bag design and efficient top mounted shaker ensures quick efficient cleaning and maximum bag life.
- Optional secondary filters.

**Metal • Cement • Bulk Powder • Plastic • Pharmaceutical
Wood • Shotblast • Food • Silo Venting**

How It Works

...during normal operation

1. During normal operation, the dust laden air from the plant travels down the extract duct **1**
2. A standard baffle **2** is mounted at the inlet of the filter to break up the air flow and direct the dust downward into the hopper section **3** while protecting the filter media from abrasive dusts.
3. The lighter dust collects on the inside of the filter bag **4** as clean air passes through. Finally, the clean air travels up through the air handling fan **5** where it could be returned to the plant or exhausted outdoors.
4. The heavier dust settles in the hopper section **3** where it is discharged into a metal bin **6**.

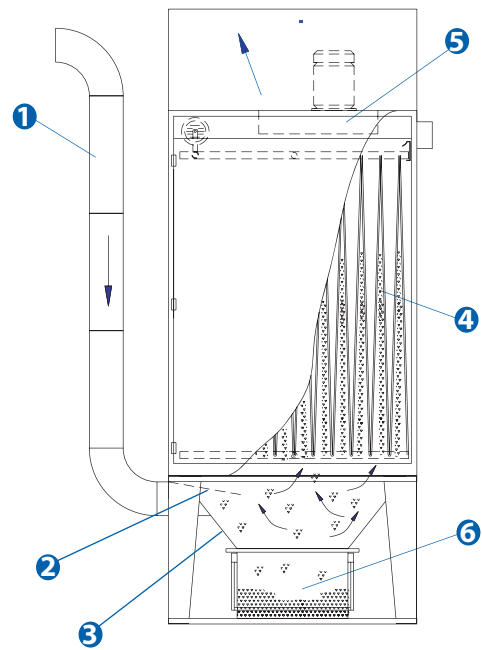

...while cleaning

1. Each time the filter unit is turned off, there is a 2 minute delay and then the automatic timer activates the shaking motor **8**.
NOTE: The cleaning cycle is set to 8 seconds.
2. The shaft of the shaker motor is attached to a simple cam which, in turn is attached to the shaking mechanism **9**. The shaking mechanism pivots vigorously which causes the dust to break free from the inside of the filter bag **4**.
3. The dust then falls into the quick-release metal collection bin located at the bottom of the filter unit **6**.

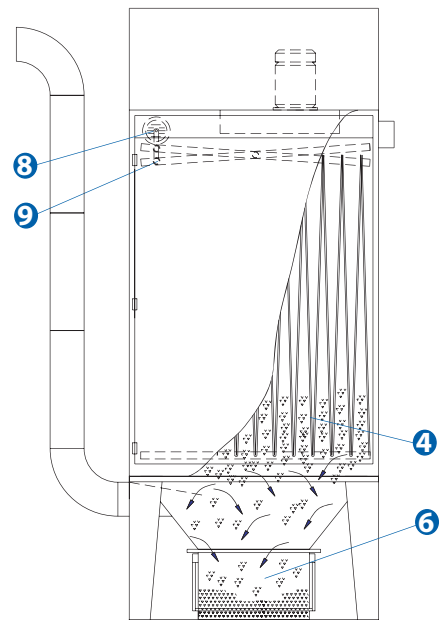

AUTO M

Planning-in Data

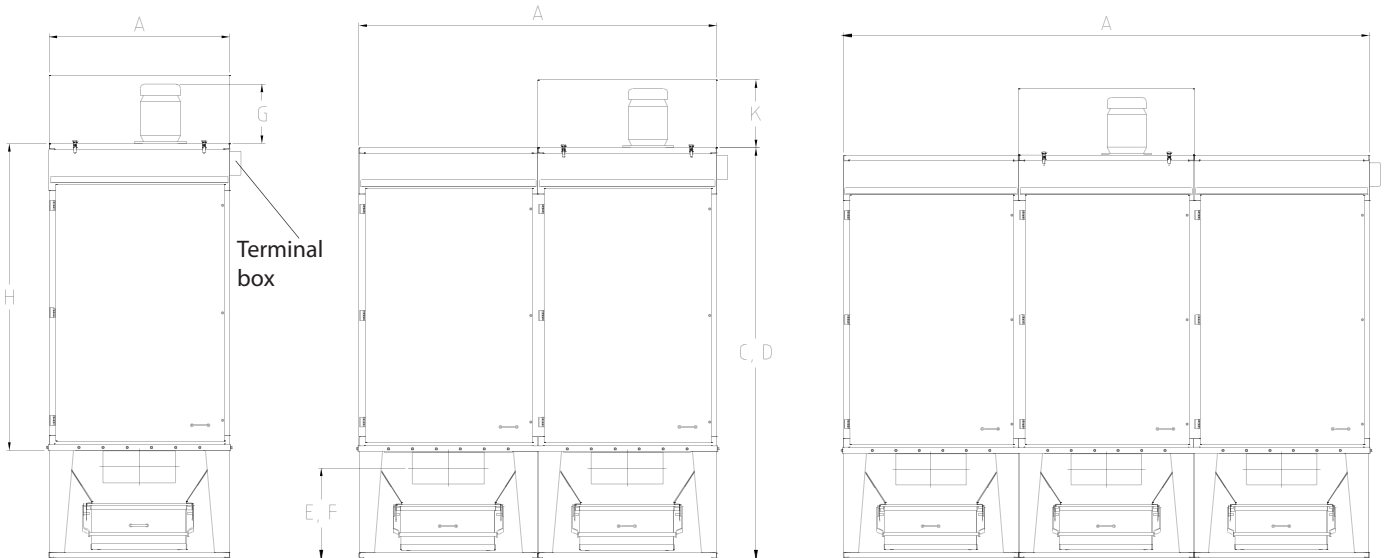

Standard Inlets on rear for Z 7.5 to Z 30 units. Side inlets optional.
 Standard inlets on rear for Z 50 to Z 90 units. Side inlets optional on Z 50 and Z 60 units.
 Z 90 must have rear inlets.

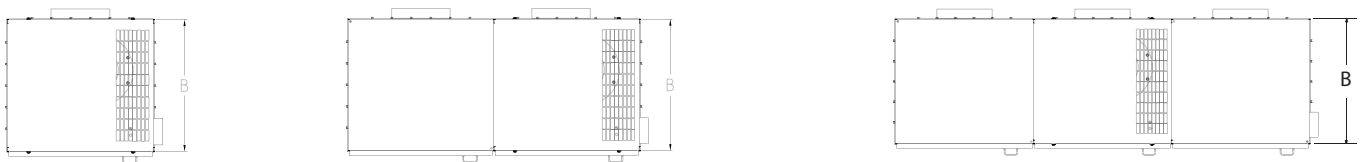

Unit Type	Leading dimensions in mm - Standard Auto M units										Max. weight kg	
	A	B	C	D	E	F	G	H	K	K	Unit with bin and largest single fan	Venting unit
	Width excluding terminal box	Depth	Filter height with 75 litre bin	Filter height with 150 litre bin	Height to c/l of inlet, 75 litre bin	Height to c/l of inlet, 150 litre bin	Height of max. size motor for unit	Vent filter with mounting flange	Height of silencer up to 7.5kW	Height of silencer 11kW and 15kW		
Z 7.5	830	750	1458	1753	485	783	245	911	425**	none	160	120
Z 15	830	750	2008	2303	485	783	245	1461	425**	none	210	160
Z 25	1120	1010	2313	2613	565	865	366	1680	425	none	310	250
Z 30	1120	1010	2567	2867	565	865	366	1937	425	none	350	290
Z 50	2240	1010	2313	2613	565	865	844*	1680	425	1100	520	420
Z 60	2240	1010	2567	2867	565	865	844*	1937	425	1100	640	500
Z 75	3360	1010	2313	2613	565	865	844*	1680	425	1100	740	550
Z 90	3360	1010	2567	2867	565	865	844*	1937	425	1100	860	680

*NOTE: shown for 11kW and 15kW fans which are externally mounted. Dimension for 7.5kW motor is 366.

**NOTE: max fan size for Z 7.5 and Z 15 is 3.0kW.

Planning-in Data

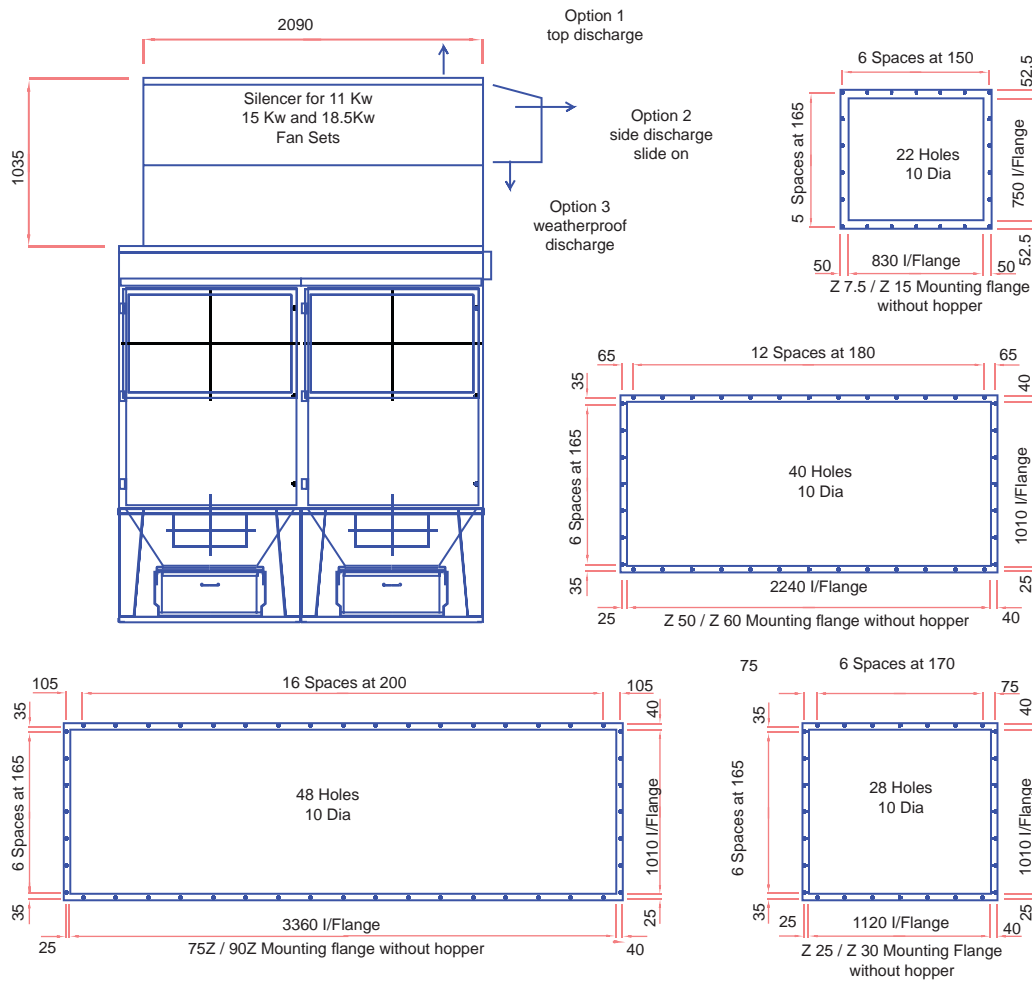

AUTO M INLET DETAILS							
Filter unit inlet details with 75 or 150 litre bin							
Unit size	Standard unit		Unit with pre-separation section - single inlet (see options)				
	Inlet spigot details	Position and number of inlets	Unit height increase with pre-separation	Inlet spigot details	Inlet position	Height from floor to centre line of inlet	
						75 litre bin	150 litre bin
Z 7,5 and Z 15	100, 125, 150 & 190 dia.	1 - side or rear	390	100, 125, 150 & 190 dia.	Side or rear	810	1110
Z 25 and Z 30	200 H x 450 W	1 - side or rear	500	200 H x 450 W	Side or rear	950	1250
Z 50 and Z 60	200 H x 450 W	2 - side or rear	500	300 H x 500 W	Side or rear	950	1250
Z 75 and Z 90	200 H x 450 W	3 - rear	500	300 H x 750 W	Side or rear	950	1250

AUTO M

Description

The filter body, with full width opening front access door, is fitted with a multi vee-pocket filter bag secured by a clamping frame at its lower end. The upper end of the bag is suspended from a frame, which can pivot about its central axis. This is in turn linked by a connecting rod to the shaker drive motor, robustly located within the unit top, below the silencer enclosure.

The filter body is normally mounted on a steel hopper onto which is fitted the dirty air inlet spigot. This can be located on either side, or if required, the rear of the hopper. Inlet connections may be specified to accept Dantherm Filtration, Ltd., QF ducting, or be plain ended if required. The hopper is fitted with a quick release bin mechanism and a rectangular steel bin of 75 or 150 litre capacity. A bin balance assembly enables the bin to be used with plastic liners to ease dust disposal.

Controllers for remote mounting are fitted with starter(s) for the fan(s) and built-in timed sequence to operate the shaker mechanism(s).

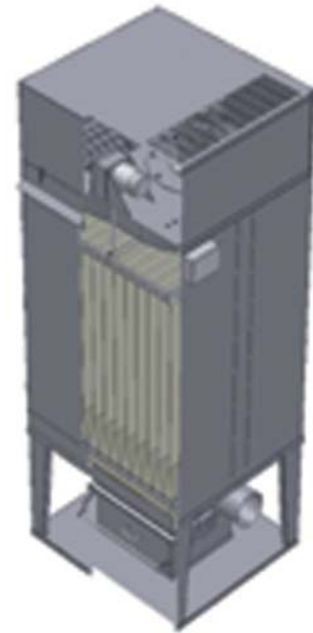

Operation

Filtering mode:

Dust laden air enters the filter via an inlet, fitted with a deflector plate, above the dust collection bin. The air passes through a vertical multi vee-pocket filter bag, which is clamped and sealed at the bottom of the filter body. Heavy dust may fall directly into the bin while other dust is arrested by the filter material. The cleaned air is drawn through a built-in radial fan and discharged directly or via an optional secondary filter.

Cleaning mode:

The top of the filter bag is suspended from a centrally pivoted frame. After the fan has stopped, this frame is made to oscillate rapidly for a few seconds by means of an electrically driven eccentric bearing within a short connecting rod, attached to the filter suspension frame. This effectively dislodges the dust from the bag.

The dust bin is released by lifting the handle in front of the bin and sliding the bin out. A bin balance assembly enables the use of a plastic liner for cleaner dust removal.

Fan Performance

Built-in fans for Z 7.5 & Z 15: 0.75, 1.1, 2.2 and 3.0kW.

Built-in fans for Z 25 & Z 30: 0.75, 1.1, 2.2, 3.0, 4.0, 5.5 & 7.5kW

Top mounted fans for Z 50 to Z 90: 11.0 & 15.0kW

**Auto M fan performance, with open outlet, at running speed 2900/min.
Built-in fans used for Auto M only.**

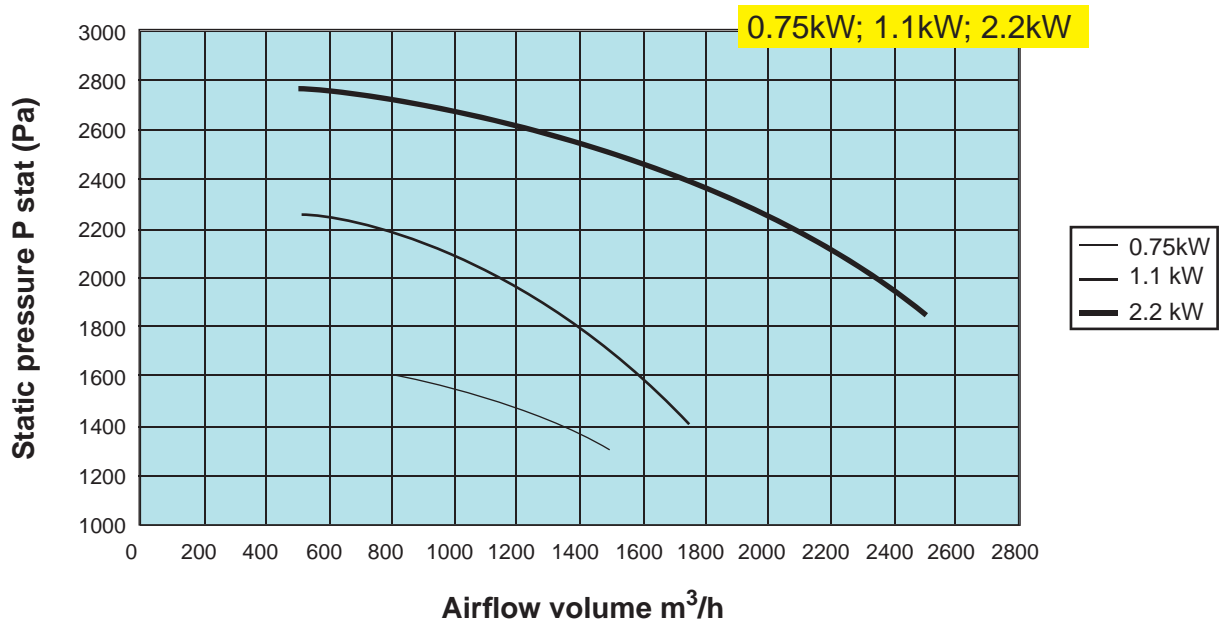

**Auto M fan performance, with open outlet, at running speed 2900/min.
Built-in fans used only on Auto M.**

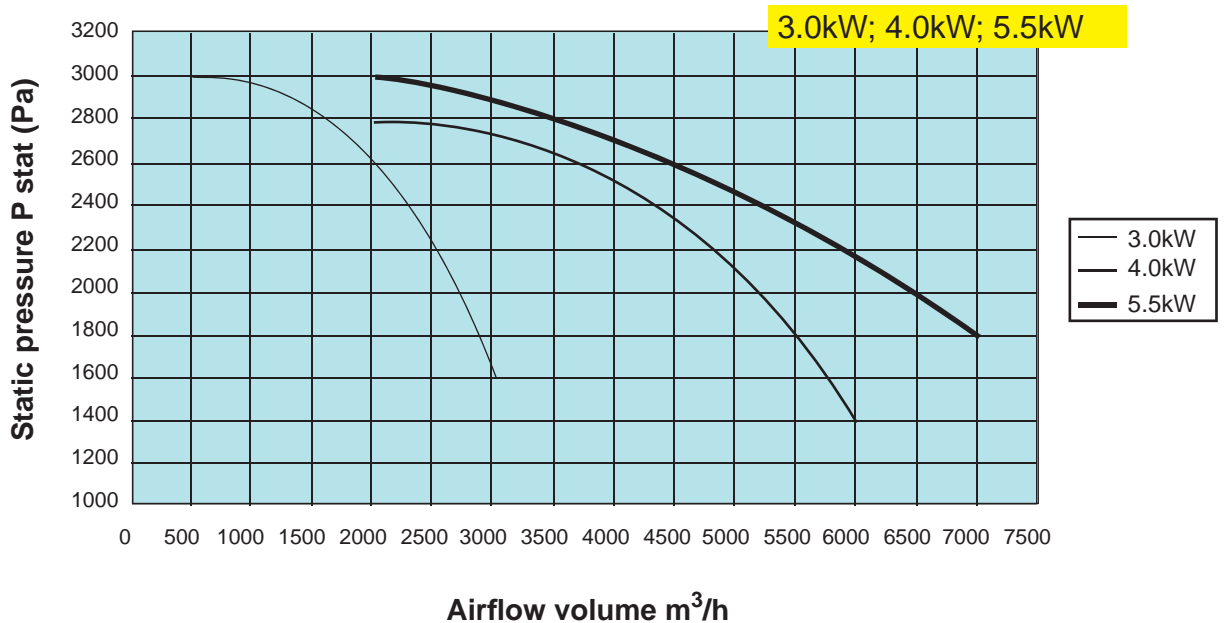

AUTO M

Fan Performance

Built-in fans for Z 7.5 & Z 15: 0.75, 1.1, 2.2 and 3.0kW.

Built in fans for Z 25 & Z 30: 0.75, 1.1, 2.2, 3.0, 4.0, 5.5 & 7.5kW

Built-in fans for Z 50 to Z 90: up to 2 x 7.5 kW

Top mounted fans for Z 50 to Z 90: 11.0 & 15.0kW

**Auto M fan performance with open outlet, at running speed 2900/min.
Built-in fans used on Auto M only. 11kW and 15 kW fans externally mounted.**

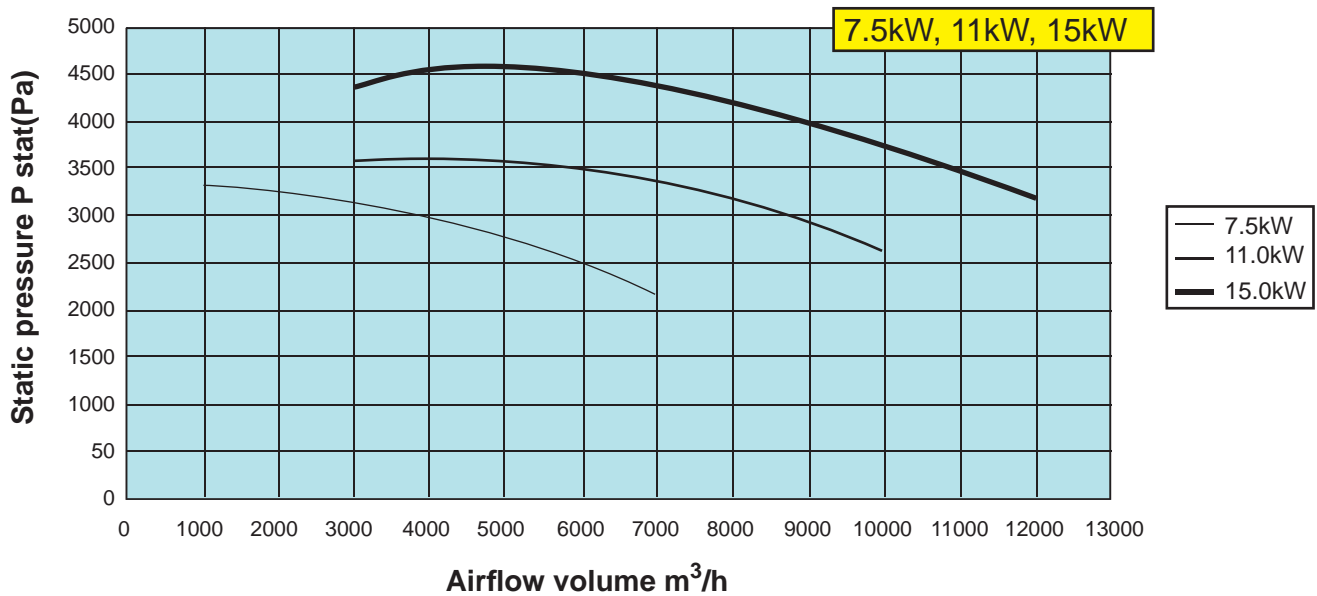

Explosion Relief Panels

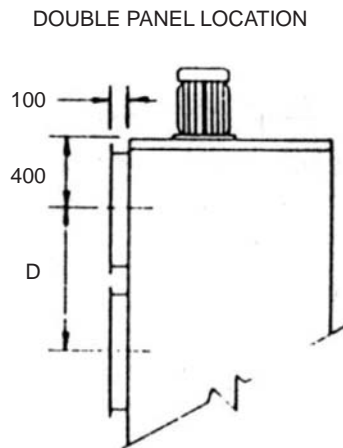
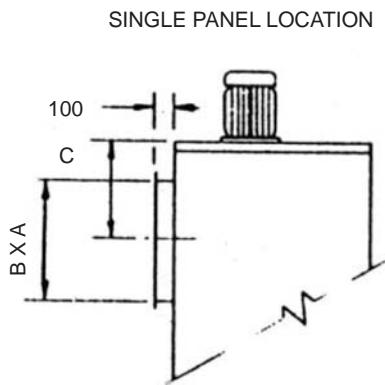

Dimensions mm				
Panel type	A	B	C	D
H1	630	600	600	800
H2	1000	600	600	800
H3	1000	880	740	910

* On units with double panels, the upper panel is always H1 or H2. 25 units only:

** For Z 7,5 and Z 15 units only C=500

The Auto M range is certified under the ATEX Directive (94/9/EC) for use with potentially explosive dusts. Z-Series units may be fitted with Dantherm Filtration, Ltd., explosion relief panels when required for use with potentially explosive dusts.

Dust explosion class				
Unit configuration	Unit size	St1	St2	St3
Units with 75 or 150 litre bins	Z - 7.5	1 - Type H1	1 - Type H1	2 - Type H1
	Z - 15	1 - Type H1	2 - Type H1	2 - Type H1
	Z - 25	1 - Type H2	1 - Type H2	1 - Type H3
	Z - 30	1 - Type H2	1 - Type H3	2 - Type H2
	Z - 50	2 - Type H2	2 - Type H2	2 - Type H3
	Z - 60	2 - Type H2	2 - Type H3	4 - Type H2
	Z - 75	3 - Type H2	3 - Type H2	3 - Type H3
Units with 75 or 150 litre bins and pre separation or spark trap	Z - 7.5	1 - Type H1	1 - Type H1	2 - Type H1
	Z - 15	1 - Type H1	2 - Type H1	2 - Type H1
	Z - 25	1 - Type H2	1 - Type H3	2 - Type H2
	Z - 30	1 - Type H2	1 - Type H3	2 - Type H2
	Z - 50	2 - Type H2	2 - Type H3	4 - Type H2
	Z - 60	2 - Type H2	2 - Type H3	4 - Type H2
	Z - 75	3 - Type H2	3 - Type H3	6 - Type H2
Venting or other open base unit with no hopper	Z - 7.5	1 - Type H1	1 - Type H1	2 - Type H1
	Z - 15	1 - Type H1	2 - Type H1	2 - Type H1
	Z - 25	1 - Type H1	1 - Type H2	1 - Type H3
	Z - 30	1 - Type H2	1 - Type H2	1 - Type H3
	Z - 50	2 - Type H1	2 - Type H2	2 - Type H3
	Z - 60	2 - Type H2	2 - Type H2	3 - Type H3
	Z - 75	3 - Type H1	3 - Type H2	3 - Type H3
Z - 90	3 - Type H2	3 - Type H2	3 - Type H3	

AUTO M

Explosion Relief Panels

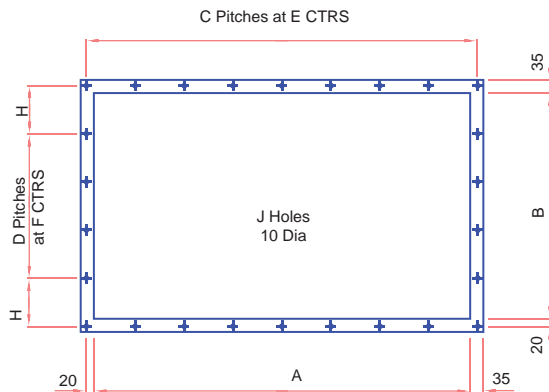

Panel Type	A	B	C	D	E	F	G	H	J
H1	630	600	5	3	134	128	500	128	20
H2	1000	600	8	3	130	128	500	128	26
H3	1000	880	8	4	130	170	640	120	28

Explosion Panel Dimensions

The Auto M filter unit range complete with the quick release dust bin has been independently tested under explosive conditions to gain certification as a protective system under the European Directive 94/9/EC (ATEX).

EC – Type Examination Certificate number: Baseefa03ATEX0225

The range, when fitted with properly sized Auto M hinged explosion panels is suitable for use with St1, St2 and St3 explosible dusts, up to $kSt=500$ bar.m/s.



The hinged explosion panels, as shown above, are fitted into a flanged frame that may be fitted with a short duct with a maximum length of 1 m to direct the ventilated material out through a wall to a safe area, if the unit is located indoors.

Note that Auto M Z Series filter units that are fitted with explosion panels should be securely fixed to the ground.

Options

Pre-separation, Bin-balance, Sack tip, Venting.

Pre-separation section

This section fits between the hopper and is delivered as an integral part of the hopper. The inlet may incorporate a spark trap if specified. A pre-separation section is beneficial for lightweight dusts, and higher dust loadings, as it provides a greater volume below the filter bag.

The pre-separation section increases the total unit height by 390 mm for Z7.5 and Z15 units; by 500 mm for all other units.



Bin-balance

The bin-balance device balances the pressure between the bin and the clean air section. It enables plastic bin liners to be used to aid the clean disposal of waste. The flexible connecting tube is long enough to enable complete withdrawal of the bin.



Sack tipping unit

This replaces the hopper and is normally mounted over a product hopper that is hand filled. When the hinged door is opened, to empty the contents of a sack, a switch starts the filter fan. When closed again, the fan stops and the cleaning cycle operates after a short delay.

Flange sizes are the same as for Z7.5, Z15, Z25 and Z30 venting units.



Venting unit

This unit has no hopper, but is mounted directly onto the vessel or silo to be ventilated. It is fitted with a mounting flange (not shown in illustration, but sizes detailed below). It may be fan-assisted, as shown, or without fan. In this case the clean air outlet is at the back, with a weather cowl. The fan assisted version should be fitted with a standard silencer and weather cowl for outdoor location. The shaker motor, shown here in optional externally mounted position, is normally located inside the filter body.



AUTO M

Options

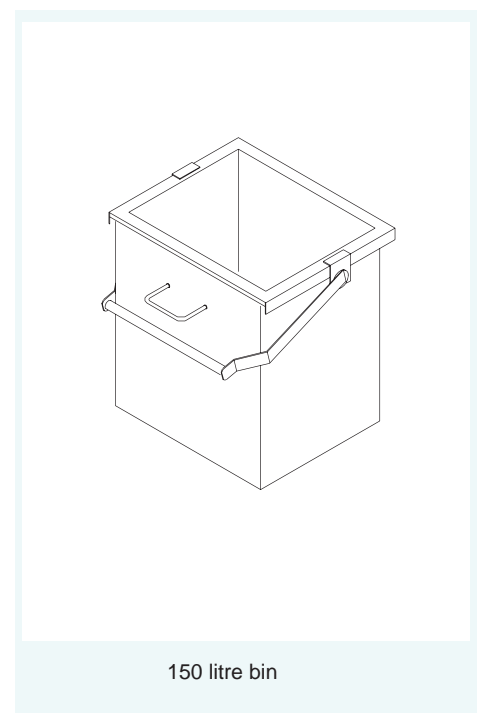
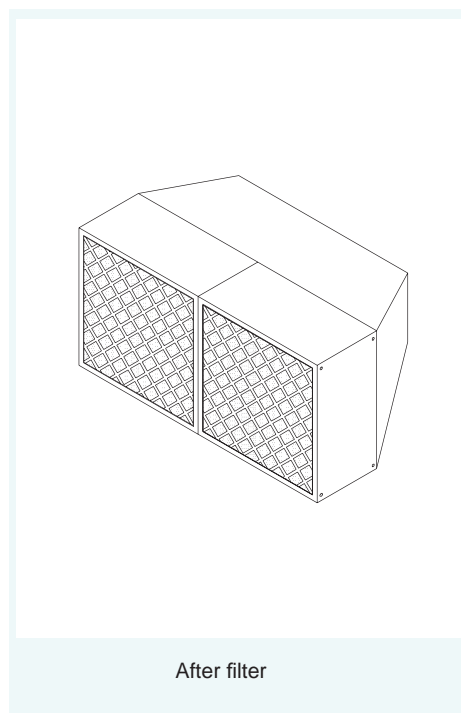
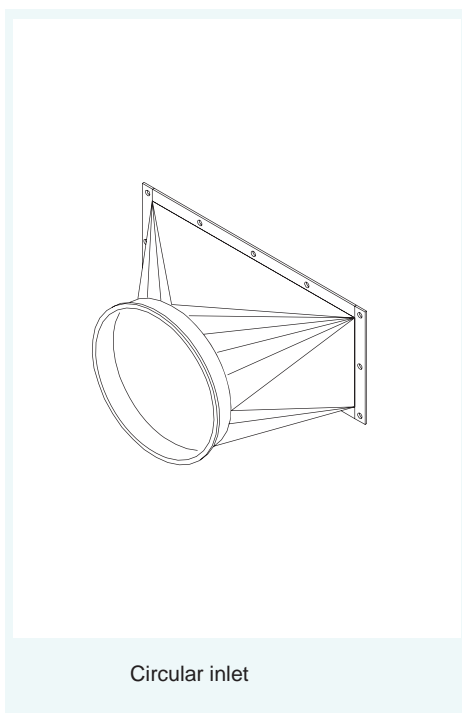
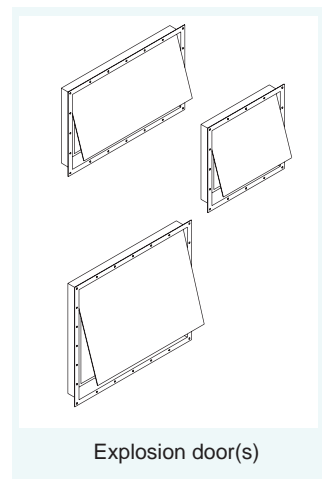
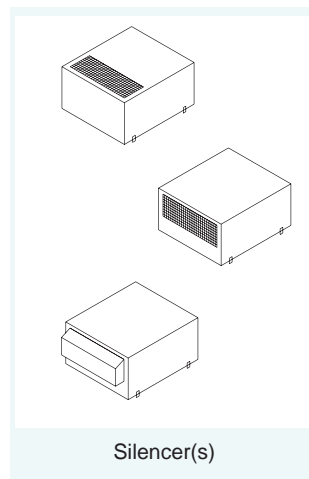
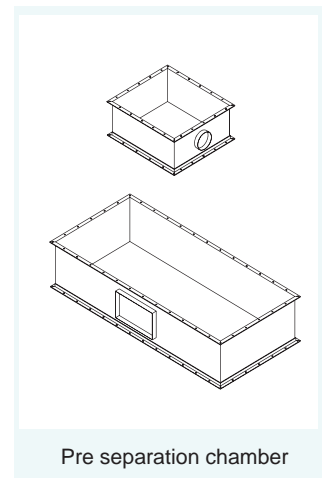
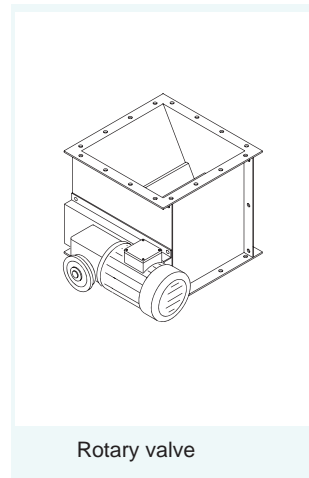
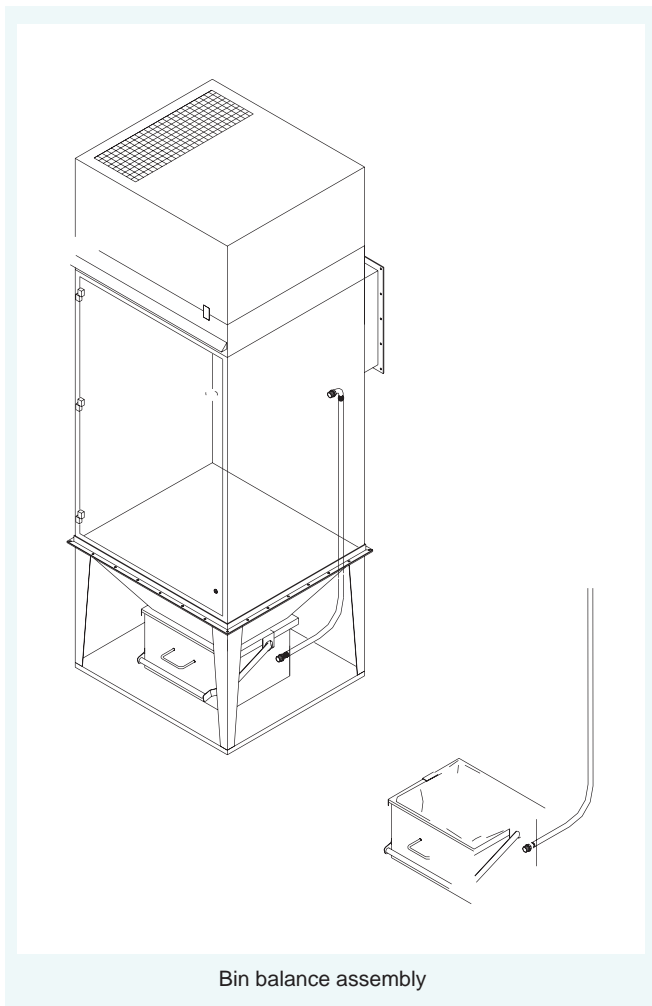

Options - Sound Attenuators

Sound Attenuators Air silencers

TOP DISCHARGE
ATTENUATOR

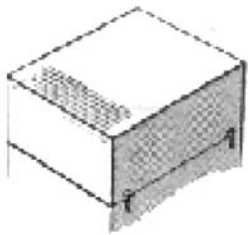

WEATHERPROOF
SIDE DISCHARGE
ATTENUATOR

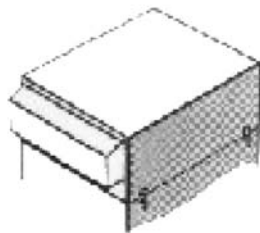

SIDE DISCHARGE
ATTENUATOR

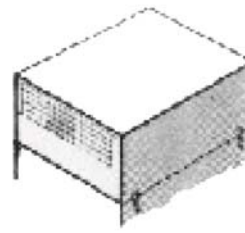

The enclosure type air silencer provides useful sound attenuation as well as enabling the Auto M unit to be located outdoors. It also reduces the shaker cleaning noise because of the location of the shaker motor. The top discharge silencer is simply lifted into place and secured with over-centre clips.

The side discharge versions also have one removable end so that it can be fitted in areas with restricted height. It is simply slid into place and the removable end then clipped into place.

Typical overall sound level at 1m distant from unit, at 1.2 m height above floor level, in an industrial location. dB(A)				Silencer weight kg
Unit	Fan size kW	Silencer fitted	No silencer	
Z 7.5 and Z 15	0.75	63	73	29
	1.1	62	72	29
	2.2	65	76	29
Z 25 up to Z 90, fitted with one fan.	1.1	62	72	45
	2.2	65	76	45
	3.0	69	78	45
	4.0	72	82	45
	7.5	76	87	45
	5.5	76	87	45
	11.0	75	86	112
15.0	80	91	112	
Z 50 up to Z 90, fitted with two fans	4.0	75	85	45 each (2 fitted)
	5.5	79	90	45 each (2 fitted)

AUTO M

Options - Secondary Filters

Secondary filters

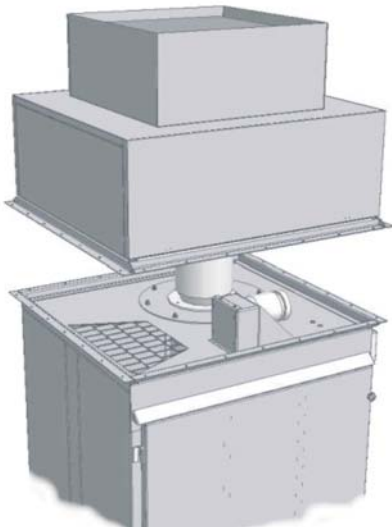

Secondary filters with classification EU7 or EU13 or equivalent may be housed within an enclosure fitted to a specially adapted air silencer, as shown. The air outlet is vertically upward. They are suitable for indoor location only.

EU7 filters are suitable as “police” filters to guard against bag failure.

EU13 filters may allow the filtered air to be returned within the building, subject to local regulations.

Note the maximum airflow volume values when selecting secondary filters.

Unit	Max. Fan Size kW	Max. airflow volume m ³ /h		Height of Silencer plus Secondary Filter
		EU7	EU13	
Z 7.5	3.0	3000	2200	825
Z 15	3.0	3000	2200	825
Z 25 & Z 30	7.5	3000	2200	825
Z 50 & Z60	2 x 5.5	6000	4400	825
Z 50 to Z90	15.0	6000	2200	1435
Z75 & Z 90	2 x 7.5	9000	6600	825

Note

World wide sales companies



The world leader in air pollution control

Dantherm Filtration focuses on individual solutions for individual customer needs. We benefit from the experience and expertise of more than 35,000 air cleaning systems. And we deliver unbeatable reliability, low energy consumption and compliance with all

mandatory requirements for a wide range of applications in many different industries all over the world.

Dantherm Filtration is part of the Dantherm Group, a leader in industrial air management,

offering industrial cooling, heating dehumidification, ventilation, air filtration and mobile air management. The group has 3,000 employees and operates globally with production and sales companies in Europe, the US and Asia.



Dantherm Filtration Co.,Ltd.
Head Office: Ekamai, Bangkok
Factory: A. Bangbuatong, Nonthaburi
Branch: A. Muang, Chonburi
 Thailand
 Tel. +66 (0) 2715 1300

Dantherm Filtration Co.,Ltd.
 Unit 403 LYS Building,
 16 Dang Tat St., Tan Dinh Ward, Dist. 1
 Ho Chi Minh City
 Vietnam
 Tel: +84 8 5265541

Dantherm Filtration Co.,Ltd.
 C2 - 33A - 02, Dataran Prima,
 Jalan PJU 1/39, 47301 Petaling Jaya,
 Selangor
 Malaysia
 Tel: +603 7804 6386